

COMPARE ADIS ADVANTAGES

- NATA tested with 300kg doors to comply with Australian Standards
- ADIS is Australian owned and Australian manufactured.
- Slim line modern design that suits the thickness of a standard wall.
- Aluminium sub-frame for side panels and door jambs.
- Compact modular design of motor drive system.
- Latest digital microprocessor controller to gain more exact control of the door operator.
- Provision to interface with building security and fire systems.
- Over engineered to take total door weights of up to 300Kg (max single leaf door weight of 150 Kg).
- No exposed wiring due to concealed wiring system.
- UPS Lithium (Uninterrupted Power Supply) can allow doors to continue to operate under a power failure. This optional extra allows the ADIS NG operator to work 800 cycles or 28hours after disruption
- Improved multiple safety features to ensure maximum user safety.
- High security electric motor locking system with battery reserve back up.
- Zone activation sensor system that uses latest presence detection technology to improve overall safety.

BACK UP SERVICE

- Fully qualified technicians to meet our high standard of company service.
- A complete 24 hour, 7 days a week, ongoing preventive maintenance service in Australian capitol cities.
- Extensive nationwide service network via our 1800 number and service agents

TECHNICAL SPECIFICATIONS

Opening width maximum single slide	2000 mm	Safety stop	Yes
Opening width maximum biparter	3000 mm	Safety return	Yes
Operator length up to	6000 mm	Safety beam shut off when closed	Yes
Total combined weight for biparting doors	300 Kg	Fire alarm activation	Yes
Door weight per leaf	150 Kg	Chime outlet	Yes
Opening speed per double leaf variable	25-1300 mm/sec	Exit only function	Yes
Closing speed per double leaf variable	25-1300 mm/sec	Battery Backup	Yes
Door open dwell time, variable	0-60 sec	UPS Lithium in all conditions	Optional
Manual opening/ closing force	<30 N	Closed positional signal	Yes
Operator size height/depth	118mm / 92mm	Operator monitor signal	Yes
Fail safe	Yes	Open closed positional signal	Yes
High security electric locking	Optional	Memory setting retained without power	Yes
Lock every cycle option	Yes	Operating Power	24 Volts
Press closed function	Yes	Appliance Rating	40 Watts
Climate control (reduced opening) function	Yes	Memory setting retained without power	Yes
Noise attenuation	32 db	4Kva power surge suppression	Yes
Keypad control	Yes	Power supply	240V/10Amp



3/413 VICTORIA STREET - WETHERILL PARK NSW 2164 AUSTRALIA

PHONE: +612 9757 4600 - FAX: +612 9757 4233

TOLL FREE PHONE: 1800 600 602 - TOLL FREE FAX: 1300 ADIS FAX

EMAIL: INFO@AUTODOORS.COM.AU

VISIT OUR WEBSITE: WWW.AUTODOORS.COM.AU

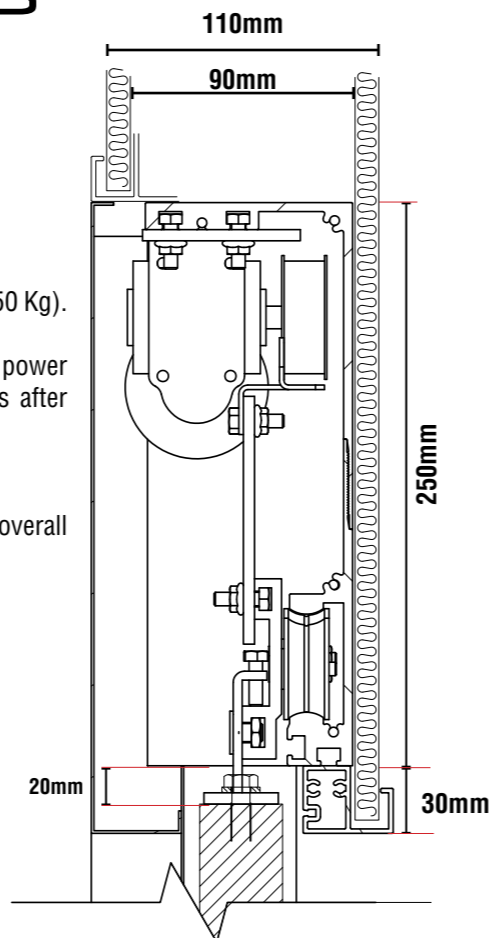

ADIS

AUTOMATIC DOORS

INTRODUCES

NGC CAVITY SLIDE



NATA Tested on doors weighing 300kg for a million cycles in compliance with AS 5007



THE NGC CAVITY SLIDE

The NGC Cavity Slide system allows a door or doors to be seamlessly slide into a cavity in a wall, the system includes the door frame, side light frame built to suit 12mm gyprock panels, track & automatic door operator.

The NGC Cavity Slide is designed for commercial applications and complies with the Building Codes requirements for automatic doors by using the advanced technology developed over the past years used in our NGA and NGF door operators.

The system comes custom made to suit your requirements either as a single sliding or biparting, with or without the door or doors. The system can be supplied assembled or in knocked down kit, the kit option allows for ease of transport especially if an elevator is needed. The optional choice of doors is variable from timber, frameless glass, aluminium framed and custom built.

Safety features include auto-reversing if obstructed and overhead mounted presence that detect a person in the doorway.

NGC CAVITY SLIDE ACCESS IMPROVEMENTS

BEFORE

AFTER

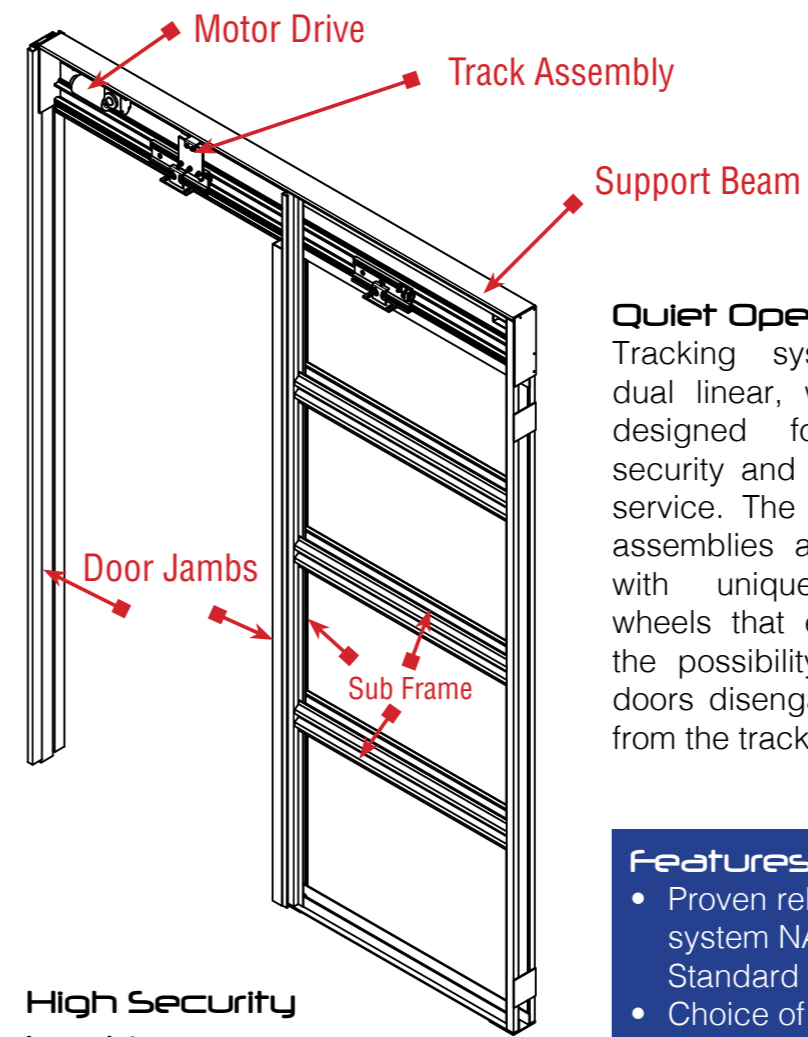

Quiet Operation

Tracking system is dual linear, which is designed for high security and long life service. The carriage assemblies are fitted with unique track wheels that eliminate the possibility of the doors disengagement from the track.



High Security Locking

The Next Generation Series operators utilizes a purpose built motor which includes an electric locking system to ensure that the doors can be securely fixed in any position. This method of locking ensures the highest level of security.



Advanced Technology

ADIS utilizes the latest in digital microprocessor technology, giving the control unit multiple programmable modes including: - provision to interface with building security system, monitoring the doors position and locks status, built-in battery. The microprocessor operating parameters can be adjusted to accommodate various climatic conditions and specific site requirements in relation to speed, braking etc. Safety is a priority: The ADIS microprocessor will automatically reverse operation while the door is closing, should the doors be obstructed. Active infrared safety sensors are included to focus across the doorway to halt and open the doors immediately upon the sensor detecting an obstruction.

Mode selector pad

A digital touch pad is supplied to control the doors mode of operation; this user-friendly device is accessible via a lock code and has the following modes: Auto, Lock, Exit, Hold open, Climate and Off.



Lithium-ion Battery UPS

The UPS optional extra delivers performance 4 times that of standard lead acid batteries, this system can deliver in excess of 800 door cycles or 28 hours of operation after a power failure.

Features:

- Proven reliable NGC Automatic door operating system NATA tested to comply with Australian Standard 5007
- Choice of activation devices to open the door including sensors, push buttons, proximity readers and card readers.
- In built failsafe system to comply with Building regulation
- Aluminium subframe to support the wall and track.
- Single or Biparting configuration
- Fully assembled or supplied in knocked down kit for ease of transport in a elevator.
- Nation wide service team back up.